

# TMC1175AE1C

## The Evaluation Board for the TMC1175AE1C

### Description

The TMC1175AE1C Evaluation Board brings all of the circuitry together for evaluating Fairchild Semiconductors' TMC1175A CMOS A/D converter and the TDC3310 10-bit D/A converter. The A/D and D/A signal paths are independent but easily configurable at the edge connector for reconstruction of A/D converter data with the D/A converter. Data is registered after the A/D and before the D/A converters. A common clock signal will drive both A/D and D/A converters. A/D and D/A converters may also be clocked independently via the edge connector.

The TMC1175AE1C is a simple two-layer printed circuit board with 100 x 160 millimeter Eurocard dimensions. The component side of the board comprises mostly ground plane with only a few interconnections. A double row 64-pin DIN male connector gives access to all power and digital signals. Analog input and output signals are available from SMA connectors.

Variable voltage references are provided for the TMC1175A and TDC3310. Configurable input and output wideband video amplifiers are provided for signal conditioning. Signal path offsets may be adjusted at the input and output amplifiers.

### Block Diagram

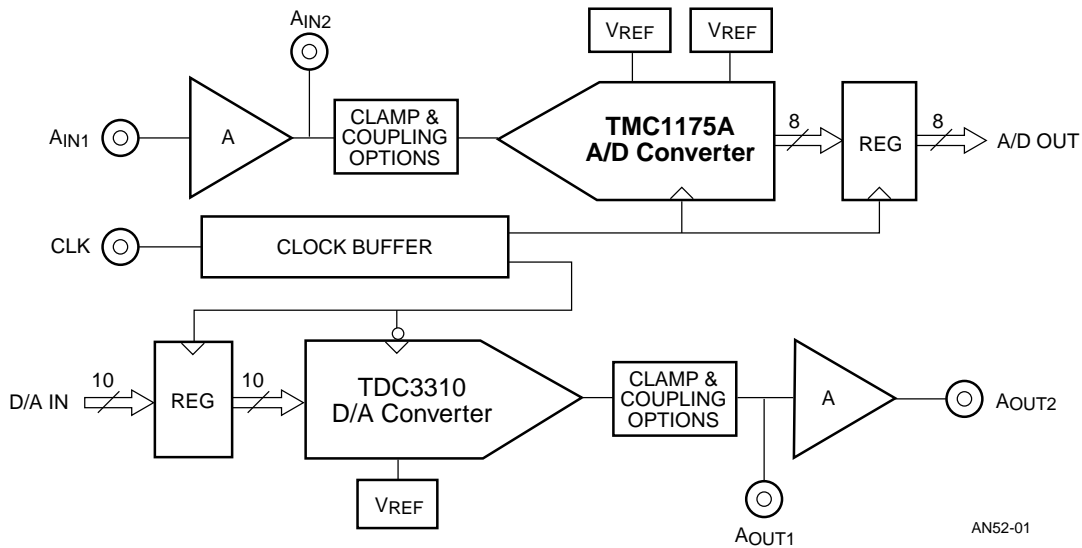

## Power Supply and Clock Input Requirements

Both the TMC1175A and TDC3310 require only +5 Volts for operation. The A/D converter voltage reference circuits and wideband amplifiers may be operated from voltages of  $\pm 5$  to  $\pm 18$  Volts.

A Clock Buffer circuit has been included on the board with a 50 $\Omega$  terminated SMA input. The clock buffer circuit provides separate CONV signals to the A/D and D/A converters and their registers. Pull-up resistors on edge-connector CLK inputs enable the clock buffer when a common clock is used. If separate clocks are desired, edge-connector pins B2 and B24 may be used for the A/D and D/A converters, respectively. The TDC3310 clock input may be monitored on test point TP1.

## TMC1175A A/D Converter Circuitry

The circuitry included on this evaluation board is not intended to represent the minimum design for A/D operation. It is designed with maximum flexibility for evaluating the TMC1175A in various configurations.

The input amplifier, U6, may be configured for inverting or noninverting operation, with and without variable offset voltage. R39 is the potentiometer used for varying the offset of the signal applied to the A/D converter. The output of the input amplifier is monitored at SMA AIN2. AIN2 may also be used as a signal input when AC-coupling to the A/D converter is used. The 75 $\Omega$  input termination resistor and voltage gain of this amplifier are jumper selectable. Fixed amplifier gains of -4, -1, +2, and +5 are available.

AC- or DC-coupling directly to the TMC1175A is accomplished via input connector AIN2. A “poor man’s” diode clamp limits the negative going AC-coupled signal to the A/D converter to the voltage applied to RT. The diode clamp and coupling method are jumper selectable. Silicon diodes are included on the board to prevent voltage excursions on the input to the A/D converter from going beyond the power supply range.

Two variable voltage reference circuits are provided on the board for driving the RT and RB inputs of the TMC1175. The A/D reference voltage inputs may be jumper configured for the internal reference divider of the TMC1175A using VR+ and VR-. Other jumper options connect RT to VCC and RB to GND. The reference inputs to the A/D converter may be monitored on test points TP5 and TP6.

Table 1 summarizes the function of each jumper and Table 2 indicates which jumpers are to be installed and removed for amplifier configurations.

**Table 1. A/D Converter Jumpers**

J14	Connects OFFSET control to inverting input of amplifier.
J15	Grounds inverting input of amplifier for non-inverting operation.
J16	Connects AIN1 to inverting amplifier input.
J17	Enables 75 $\Omega$ termination resistor on AIN1
J18	Connects AIN1 to non-inverting amplifier input.
J19	Connects OFFSET control to non-inverting input of amplifier.
J20	Decreases feedback resistor of amplifier from 4.99k $\Omega$ to 1.0k $\Omega$ .
J21	Connects amplifier output to A/D input.
J22	DC couples amplifier output to A/D input.
J23	Enables 75 $\Omega$ termination resistor on AIN2.
J24	Enables diode clamp.
J25	Connects A/D RT to VR+ pin.
J26	Connects A/D RT to VCC.
J27	Connects A/D RT to variable voltage reference.
J28	Connects A/D RB to ground.
J29	Connects A/D RB to VR pin.
J30	Connects A/D RB to variable voltage reference.

**Table 2. Jumpers for A/D Input Configurations**

Configuration		Installed	Removed
1	Non-inverting, with offset control	J14 J18	J15 J16 J19
2	Inverting, with offset control	J16 J19	J14 J15 J18
3	Non-inverting, without offset control	J15 J18	J14 J16 J19
4	AC-coupled direct input on AIN2 (with termination and clamp)	J23 J24	J21 J22
5	DC-coupled direct input on AIN2 (without termination and clamp)	J22	J21 J23 J24

## TDC3310 D/A Converter Circuitry

The D/A converter circuitry included on the Evaluation Board is not intended to represent the minimum design for D/A operation. It is designed with maximum flexibility for evaluating the TDC3310 in configurations that work for various applications and implementations. Since the TDC3310 is a 10-bit D/A converter, its two LSBs are jumpered to ground, enabling 8-bit operation, matching the resolution of the TMC1175A A/D converter. The INVERT input to the TDC3310 is grounded by jumper J4.

A simple band-gap voltage reference and potentiometer R7 provide a variable reference to the TDC3310. Varying R7 will change the “gain” of the TDC3310 D/A converter. The reference is set to -1.0 Volts with respect to the +5 Volt power supply as part of the factory test procedure. The adjustment ranges from -0.4 to -1.2 Volts with respect to the +5 Volt power supply. The TDC3310 reference voltage may be monitored on test point TP2.

AC- or DC-coupling directly from the TDC3310 to the output amplifier is accomplished via jumper J6. SMA connector AOUT1 can be used as a monitor point for the input to the output amplifier or as an un-amplified D/A converter output. A “poor man’s” diode clamp limits the negative going AC-coupled signal from the D/A converter to GND. The diode clamp is jumper selectable.

The wideband video output amplifier, U5, may be configured for inverting ( $A_V = -2$ ) or noninverting ( $A_V = +2$ ) operation with variable offset voltage from R16. The amplifier has an output series resistor of  $75\Omega$  to ensure 1 Volt pk-pk video levels into  $75\Omega$  terminated cables.

To reduce the common-mode power supply noise sensitivity of the output amplifier, the user can connect it differentially (Table 4, Configurations 5 through 8). Here, since the output

of the D/A converter is referred to the +5 Volt power supply, the complementary input of the amplifier is resistively derived from the same supply. This configuration reduces the effect of common-mode noise from the power supply at the input to the amplifier.

Table 3 summarizes the function of each jumper and Table 4 indicates which jumpers are to be installed and removed for output amplifier configurations.

**Table 3. D/A Converter Jumpers**

J1	Enables $51\Omega$ termination resistor on D/A CLK.
J2	Grounds LSB of D/A converter for 8-bit operation.
J3	Grounds 2nd LSB of D/A converter for 8-bit operation.
J4	Grounds INVERT input to D/A.
J5	Enables $75\Omega$ termination resistor on AOUT1 connector.
J6	DC couples output of D/A converter.
J7	Enables diode clamp.
J8	Connects inverting input of amplifier to VCC.
J9	Connects AC-coupled output of D/A to amplifier.
J10	Grounds inverting input of amplifier.
J11	Connects non-inverting input of amplifier to VCC.
J12	Connects non-inverting input of amplifier to D/A output.
J13	Connects non-inverting input of amplifier to ground.

**Table 4. Jumpers for D/A Output Amplifier Configurations**

Configuration	Coupling	Referred	Installed	Removed
1 Non-inverting	AC	GND	J10 J12	J6 J8 J9 J11 J13
2 Inverting	AC	GND	J9 J13	J6 J8 J10 J11 J12
3 Non-inverting	DC	GND	J6 J10 J12	J8 J9 J11 J13
4 Inverting	DC	GND	J6 J9 J13	J8 J10 J11 J12
5 Non-inverting	AC	VCC	J8 J12	J6 J9 J10 J11 J13
6 Inverting	AC	VCC	J9 J11	J6 J8 J10 J12 J13
7 Non-inverting	DC	VCC	J6 J8 J12	J9 J10 J11 J13
8 Inverting	DC	VCC	J6 J9 J11	J8 J10 J12 J13

## The Edge Connector

The edge connector has been arranged to easily configure the board for reconstructing A/D data with the TDC3310 D/A converter. A/D data outputs are located exactly adjacent to D/A data inputs on the edge connector. Simply shorting these edge connector pins together will enable the direct transfer of data from one signal path to the other.

**Table 5. Edge-connector Pin Assignments**

A32	GND	B32	V- (-15V)
A31	GND	B31	V+ (+15V)
A30	GND	B30	N/C
A29	GND	B29	N/C
A28	GND	B28	N/C
A27	GND	B27	N/C
A26	GND	B26	N/C
A25	GND	B25	N/C
A24	GND	B24	D/A CONV Input
A23	GND	B23	N/C
A22	GND	B22	N/C
A21	D/A D <sub>1</sub> MSB	B21	A/D D <sub>1</sub> MSB
A20	D/A D <sub>2</sub>	B20	A/D D <sub>2</sub>
A19	D/A D <sub>3</sub>	B19	A/D D <sub>3</sub>
A18	GND	B18	V <sub>CC</sub> (+5V)
A17	D/A D <sub>4</sub>	B17	A/D D <sub>4</sub>
A16	D/A D <sub>5</sub>	B16	A/D D <sub>5</sub>
A15	D/A D <sub>6</sub>	B15	A/D D <sub>6</sub>
A14	D/A D <sub>7</sub>	B14	A/D D <sub>7</sub>
A13	D/A D <sub>8</sub>	B13	A/D D <sub>8</sub> LSB
A12	D/A D <sub>9</sub>	B12	N/C
A11	D/A D <sub>10</sub> LSB	B11	N/C
A10	N/C	B10	N/C
A9	N/C	B9	N/C
A8	N/C	B8	N/C
A7	N/C	B7	N/C
A6	N/C	B6	N/C
A5	N/C	B5	N/C
A4	GND	B4	N/C
A3	GND	B3	N/C
A2	GND	B2	A/D CONV Input
A1	GND	B1	V <sub>EE</sub> (-5.2V)

# Schematic Diagrams

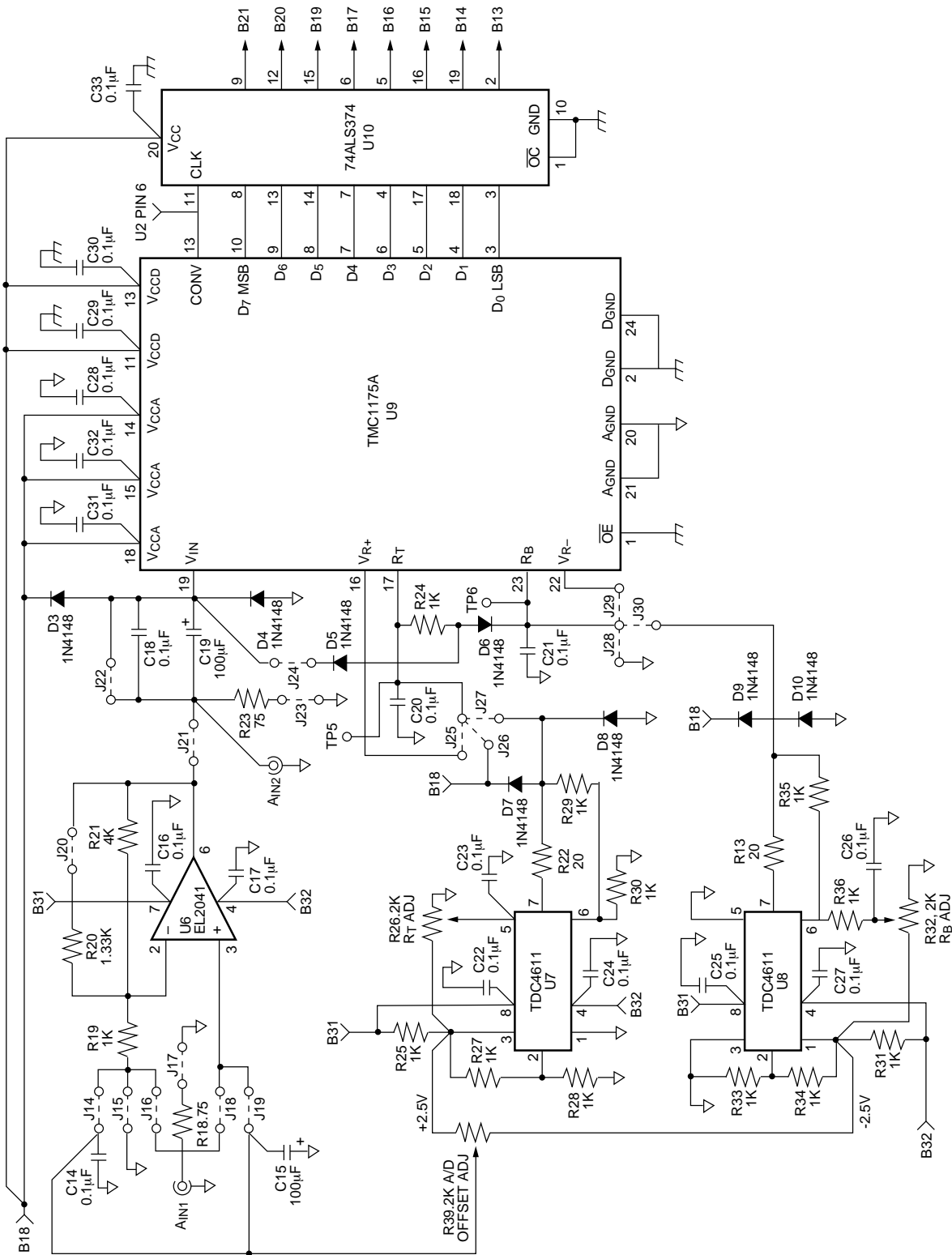

Figure 2. A/D Converter

Schematic Diagrams (continued)

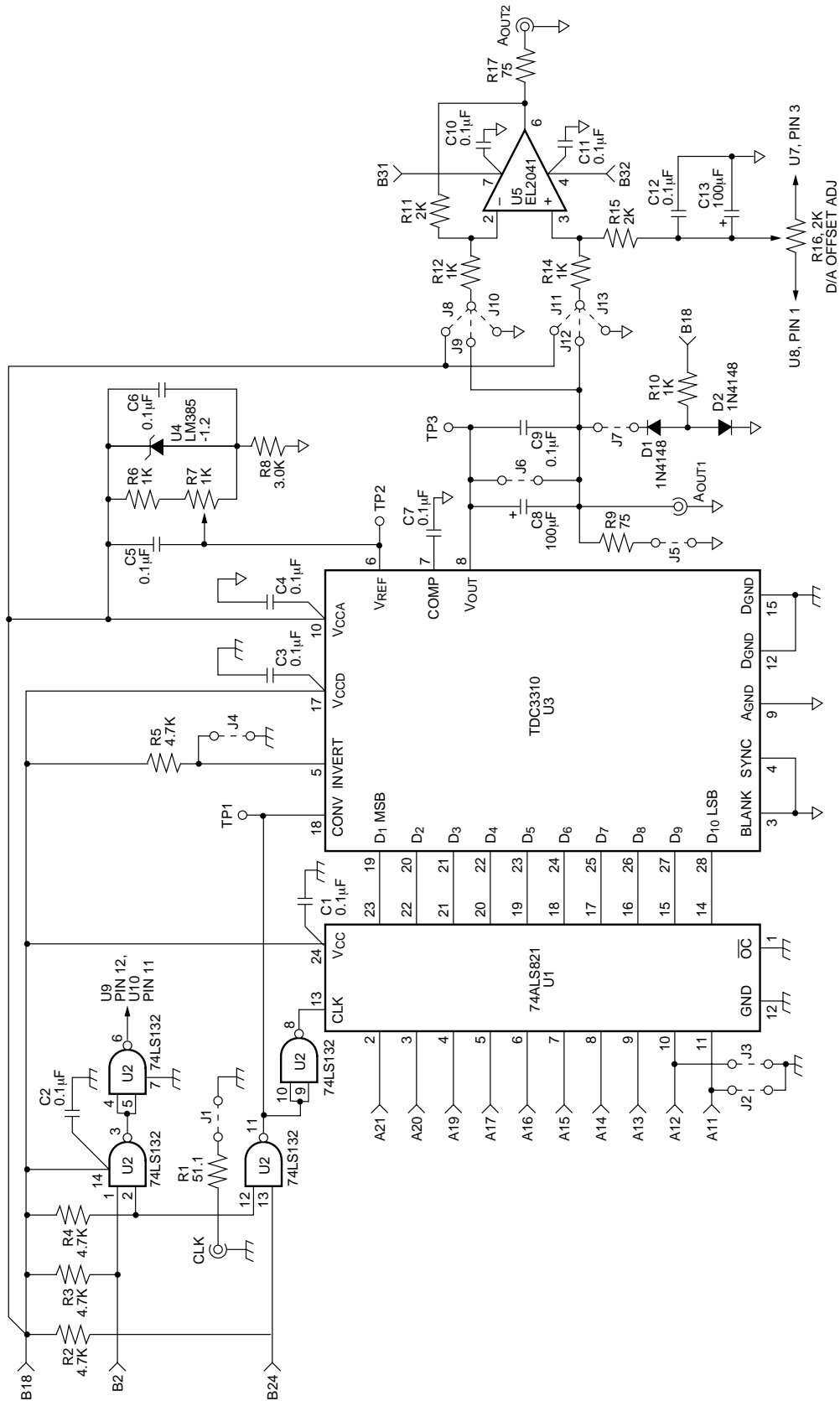

Figure 3. D/A Converter

Table 6. Parts List

Item	Qty	Part/Value	Ref. Designator	Mfg. P/N
1	1	Resistor, 51.1 $\Omega$	R1	RN55D51R1F
2	4	Resistor, 4.75k $\Omega$	R2-R5	RN55D4751F
3	16	Resistor, 1.0k $\Omega$	R6, R10, R12, R14, R19, R24-R25, R27-R31, R33-R36	RN55D1001F
4	1	Potentiometer, 2k $\Omega$	R7	RJ26FW202
5	1	Resistor, 2.94k $\Omega$	R8	RN55D2941F
6	4	Resistor, 75 $\Omega$	R9, R17, R18, R23	RN55D75R0F
7	2	Resistor, 2.0k $\Omega$	R11, R15	RN55D2001F
8	2	Resistor, 20 $\Omega$	R13, R22	RN55D20R0F
9	4	Potentiometer, 2k $\Omega$	R16, R26, R32, R39	3006Y-1-202, 3006P-1-202
10	1	Resistor, 1.30k $\Omega$	R20	RN55D1301F
11	1	Resistor, 4.02k $\Omega$	R21	RN55D4021F
12	29	Capacitor, 0.1 $\mu$ F, 50WVDC, 20% Tol.	C1-C7, C9-C12, C14, C16-C18, C20-C33	AVX: SR215E104MAA, CK05BX104K Kemet: C322C104M5U5CA, C052C104K5X5CA Murata-Erie: RPE122Z5U104M50V
13	4	Capacitor, 100 $\mu$ F, 10WVDC, 20% Tol.	C8, C13, C15, C19	AVX: TAP107K010HSB Kemet: T354E107K01AS
14	1	10-bit register	U1	74AS821NT
15	1	Quad NAND	U2	74LS132N
16	1	10-bit Video D/A	U3	TDC3310N6C, Fairchild
17	1	Reference 1.2 V	U4	LT1004CH-1.2
18	2	Video Amplifier	U5, U6	EL2041CN
19	2	Reference/Amplifier	U7, U8	LM611CN, National
20	1	8-bit A/D	U9	TMC1175AN2C, Fairchild
21	1	8-bit Register	U10	74ALS374
22	10	0.2 AMP 100V D035	D1-D10	1N4148
23	1	Eurocard Connector DIN 41612 2-Row 64-Contact Board Mount Male		Amphenol 704-C133-714A-64P, Winchester 64P-6033-0430
24	5	SMA Coax Connector	AIN1, AOUT2, CLK, AIN2, AOUT1	Omni-Spectra 2062-0000-00, Sealectro 50-561-000-31
25	1	24 Pin DIP 0.300" Row Spacing I.C. Socket	U9	Robinson-Nugent ICA-243-S-TG or Equivalent
26	1	28 Pin DIP 0.600" Row Spacing I.C. Socket	U3	Robinson-Nugent ICA-286-S-TG or Equivalent
27	7	0.025" Square Post Header, 2 Contacts 0.100" Spacing	J1, J4-J7, J20, J23	Robinson-Nugent NSH-02SB-S2-TR
28	1	0.025" Square Post Header, 3 Contacts 0.100" Spacing	J18-J19	Robinson-Nugent NSH-03SB-S2-TR
29	1	0.025" Square Post Header, 4 Contacts 0.100" Spacing	J2-J3	Robinson-Nugent NSH-04DB-S2-TR
30	1	0.025" Square Post Header, 6 Contacts 0.100" Spacing	J21-J22, J24	Robinson-Nugent NSH-06DB-S2-TR

**Table 6. Parts List** (continued)

Item	Qty	Part/Value	Ref. Designator	Mfg. P/N
31	1	0.025" Square Post Header, 8 Contacts 0.100" Spacing	J14-J17	Robinson-Nugent NSH-08DB-S2-TR
32	2	0.025" Square Post Header, 12 Contacts 0.100" Spacing	J8-J13, J25-J30	Robinson-Nugent NSH-12DB-S2-TR
33	11	Header Programming Shunts	J6, J9, J11, J14, J17, J18, J20- J22, J27, J30	Robinson-Nugent HPS-03-G
34	1	Universal Transistor Mount	U4	Bivar 111-80
35	2	2-56 x 7/16 Machine Screws		
36	2	2-56 Nuts		
37	2	#2 Flat Washer		
38	2	#2 Locking Washer		
39	1	Bare P.C. Board TMC1175/ TDC3310E1C Rev. B		



# PC Board Layout

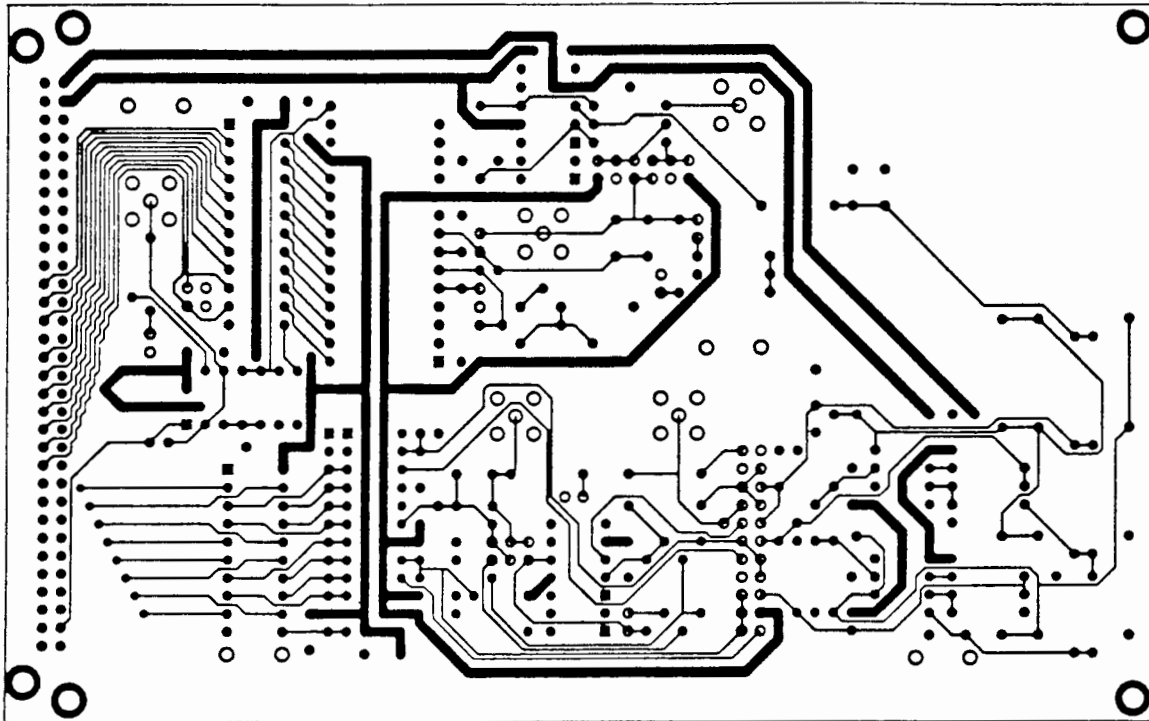

Figure 4. PC Board Circuit-Side Layout

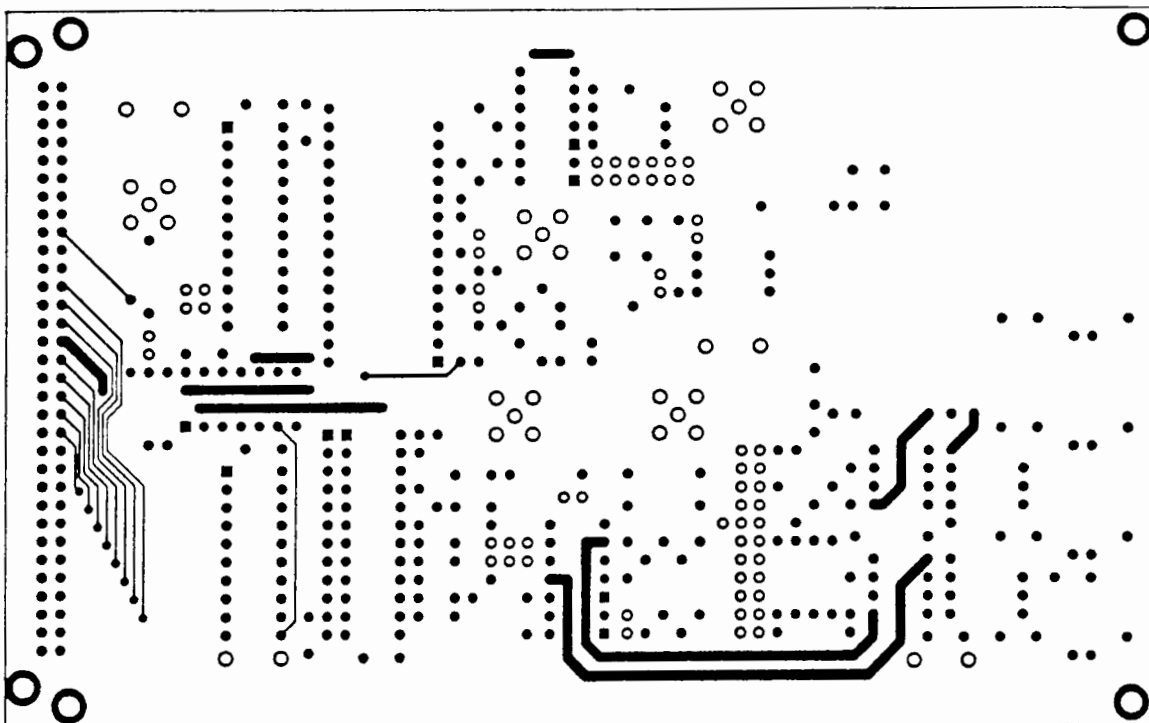

Figure 5. PC Board Component-Side Layout

### PC Board Layout (continued)

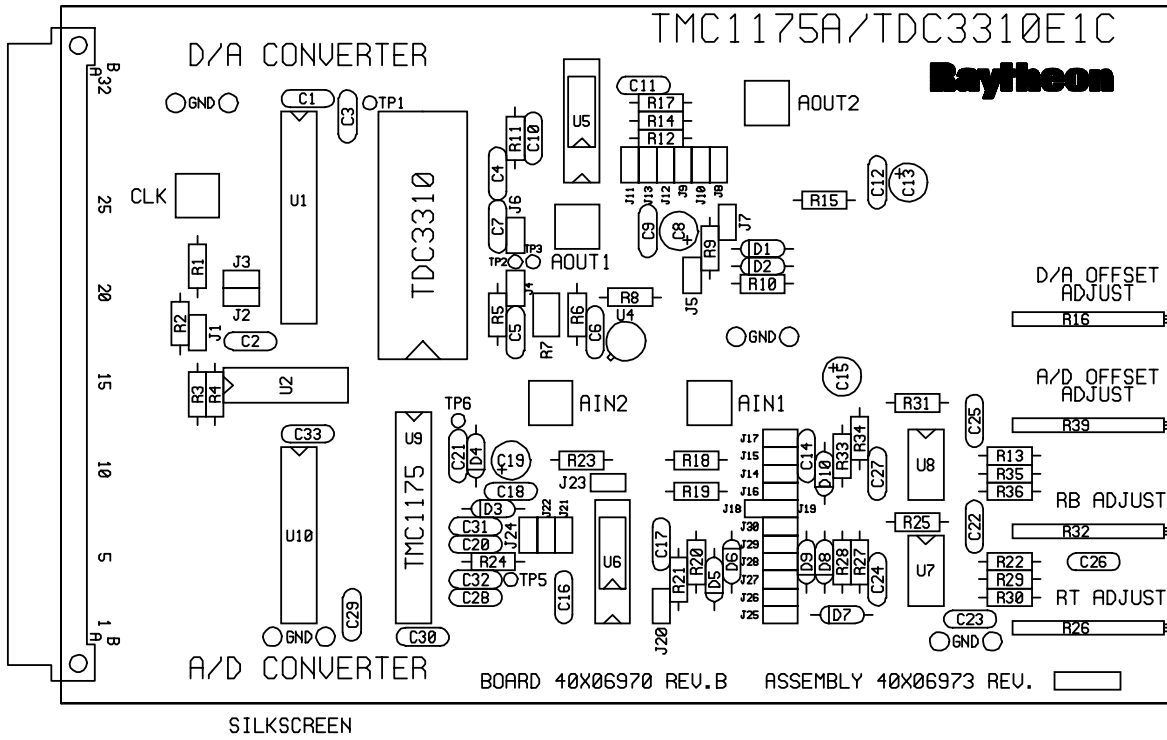

Figure 6. PC Board Silkscreen Layout

**Notes:**

## Ordering Information

Product Number	Temperature Range	Screening	Package	Package Marking
TMC1175AE1C	25°C	Commercial	4" by 6" Printed Circuit Board	TMC1175/TDC3310E1C

### LIFE SUPPORT POLICY

FAIRCHILD'S PRODUCTS ARE NOT AUTHORIZED FOR USE AS CRITICAL COMPONENTS IN LIFE SUPPORT DEVICES OR SYSTEMS WITHOUT THE EXPRESS WRITTEN APPROVAL OF THE PRESIDENT OF FAIRCHILD SEMICONDUCTOR CORPORATION. As used herein:

1. Life support devices or systems are devices or systems which, (a) are intended for surgical implant into the body, or (b) support or sustain life, and (c) whose failure to perform when properly used in accordance with instructions for use provided in the labeling, can be reasonably expected to result in a significant injury of the user.
2. A critical component in any component of a life support device or system whose failure to perform can be reasonably expected to cause the failure of the life support device or system, or to affect its safety or effectiveness.